



中国认可
国际互认
检测
TESTING
CNAS L0823



201719001121

广州市微生物研究所
GUANG ZHOU INSTITUTE OF MICROBIOLOGY
广州工业微生物检测中心
GUANG ZHOU TESTING CENTER OF INDUSTRIAL MICROBIOLOGY

检测报告
TEST REPORT

Report Number

KJ20181785

Name of Sample

Airfree Air Sterilizer

Applicant

Jebsen Consumer Products (China)

Company Limited





中国认可
国际互认
检测
TESTING
CNAS L0823



201719001121

Test No.KJ20181785

GUANG ZHOU INSTITUTE OF MICROBIOLOGY
GUANGZHOU TESTING CENTER OF INDUSTRIAL MICROBIOLOGY
TEST REPORT

Date Received: Oct. 15, 2018

Date Analyzed: Oct. 15, 2018

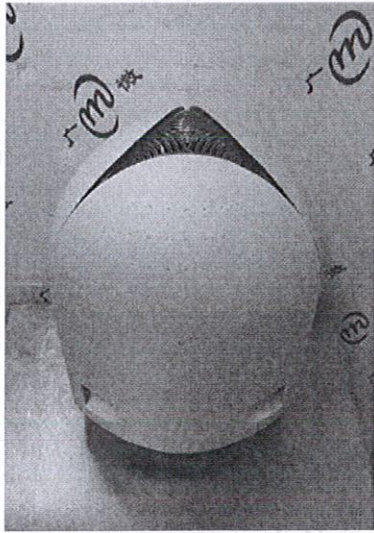
Name of Sample	Airfree Air Sterilizer	Source of Sample	Delivery
Applicant	Jebsen Consumer Products (China) Company Limited	Client	Lao Yanyi
Manufacturer	Airfree Produtos Electronicos, S.A.,	Brand	AirFree
Type and Specification	Babyair	Quantity of Sample	1PC
Date of Production	---	State of Sample	Machine
Batch Number	---	Packing of Sample	In box
Sample Picture			
Standard and Methods	<ol style="list-style-type: none"> 1. GB/T 18801-2015 Air cleaner 2. GB 21551.3-2010 Antibacterial and cleaning function for household and similar electrical appliances-Particular requirements of air cleaner 3. *GB/T 4214.1-2017 The method for noise of household and similar electrical appliances-General requirements 		
Items of Analysis	<ol style="list-style-type: none"> 1. Eliminating Bacterial Rate (<i>Pseudomonas aeruginosa</i> ATCC15442, <i>Salmonella typhimurium</i> CMCC50115) 2. Noise 		
Remarks	---		

To be continued



GUANG ZHOU INSTITUTE OF MICROBIOLOGY
GUANGZHOU TESTING CENTER OF INDUSTRIAL MICROBIOLOGY

TEST REPORT

Date Received: Oct. 15, 2018
Date Analyzed: Oct. 15, 2018

Test Method for Air Purifier Disinfection Performance:

1. Test Equipment
 - 1) Strain: *Pseudomonas aeruginosa*, *Salmonella typhimurium*
 - 2) Microbial aerosol generator: TK-3
 - 3) Culture media: NA
 - 4) Sampling equipment: six-stage sieve sampler
2. Test Conditions
 - 1) The volume of the test chamber: 3 m³
 - 2) Environment temperature: (20~25) °C
 - 3) Environment humidity: (50~70) %RH
3. Operation Conditions of the Air Purifier
The test process was electrified.
4. Test Procedure
 - 1) Get a bacteria slant culture (4~7 generation) which is incubated at 37 °C for 24 h, wash the culture from this slant with 10 mL NB, filter the liquid culture by aseptic cotton buds, and dilute this inoculums with NB as appropriate.
 - 2) The equipments are placed in the test chambers, close the door, and turn on the HEPA filter system. Simultaneously operate the environmental control devices until the temperature reaches 20 °C~25 °C, relative humidity reaches 50-70%. Turn off the chamber environmental control system.
 - 3) Release microbial aerosol: turn on the microbial aerosol generator, then turn on the ceiling fan, turn off the fan after 10 min, and let stand for 15 min.
 - 4) Original bacteria aerosols collected by six-stage sieve sampler.
 - 5) Turn on the fan during the test. The air purifier are adjusted to the highest air cleaning mode setting for test (test group). Bacteria aerosols (control group and test group) are collected at 60 min .
 - 6) Choose 2 NA plates (the same batch) as the negative control, and culture them on the same condition with the samples.
 - 7) Run the test three times and take the mean as the final result.

5. Computational Formula

$$\text{Natural decay rate } N_t(\%) = \frac{V_0 - V_t}{V_0} \times 100$$

Where: V_0 = original bacteria count of control group; V_t = bacteria count after treatment of control group.

$$\text{Killing Rate } K_t(\%) = \frac{V_1 \times (1 - N_t) - V_2}{V_1 \times (1 - N_t)} \times 100$$

Where: V_1 = original bacteria count of test group; V_2 = bacteria count after treatment of test group.

To be continued



中国认可
国际互认
检测
TESTING
CNAS L0823



201719001121

Test No.KJ20181785

GUANG ZHOU INSTITUTE OF MICROBIOLOGY
GUANGZHOU TESTING CENTER OF INDUSTRIAL MICROBIOLOGY

TEST REPORT

Date Received: Oct. 15, 2018

Date Analyzed: Oct. 15, 2018

Test Results

Number of Sample	Test Time (min)	Test Strain	Test Number	Control Group			Test Group		Killing Rate K_t (%)
				Original Bacteria Count V_0 (cfu/m ³)	Bacteria Count after Treatment V_t (cfu/m ³)	Natural Decay Rate N_t (%)	Original Bacteria Count V_1 (cfu/m ³)	Bacteria Count after Treatment V_2 (cfu/m ³)	
KJ20181785-1	60	<i>Pseudomonas aeruginosa</i>	1	1.28×10^5	8.76×10^4	31.56	1.25×10^5	7.81×10^3	90.87
			2	1.22×10^5	8.27×10^4	32.21	1.19×10^5	7.24×10^3	91.03
			3	1.32×10^5	8.85×10^4	32.95	1.33×10^5	8.41×10^3	90.57
			Mean						
		<i>Salmonella typhimurium</i>	1	1.18×10^5	7.17×10^4	39.24	1.27×10^5	7.24×10^3	90.62
			2	1.13×10^5	6.93×10^4	38.67	1.16×10^5	6.78×10^3	90.47
			3	1.23×10^5	7.24×10^4	41.14	1.05×10^5	6.08×10^3	90.16
			Mean						

To be continued



中国认可
国际互认
检测
TESTING
CNAS L0823



201719001121

Test No.KJ20181785

GUANG ZHOU INSTITUTE OF MICROBIOLOGY
GUANGZHOU TESTING CENTER OF INDUSTRIAL MICROBIOLOGY

TEST REPORT

Date Received: Oct. 15, 2018

Date Analyzed: Oct. 15, 2018

Measuring of Noise:

1. Test Environment: semi-anechoic chamber; Background Noise: 12.0 dB(A)
2. Operational Conditions of the Machine
The test process was electrified.
3. Testing Envelope Surface: hemisphere envelope surface; Testing Radius: $r=1.5$ m. Test schematic diagrams are showed as follows:

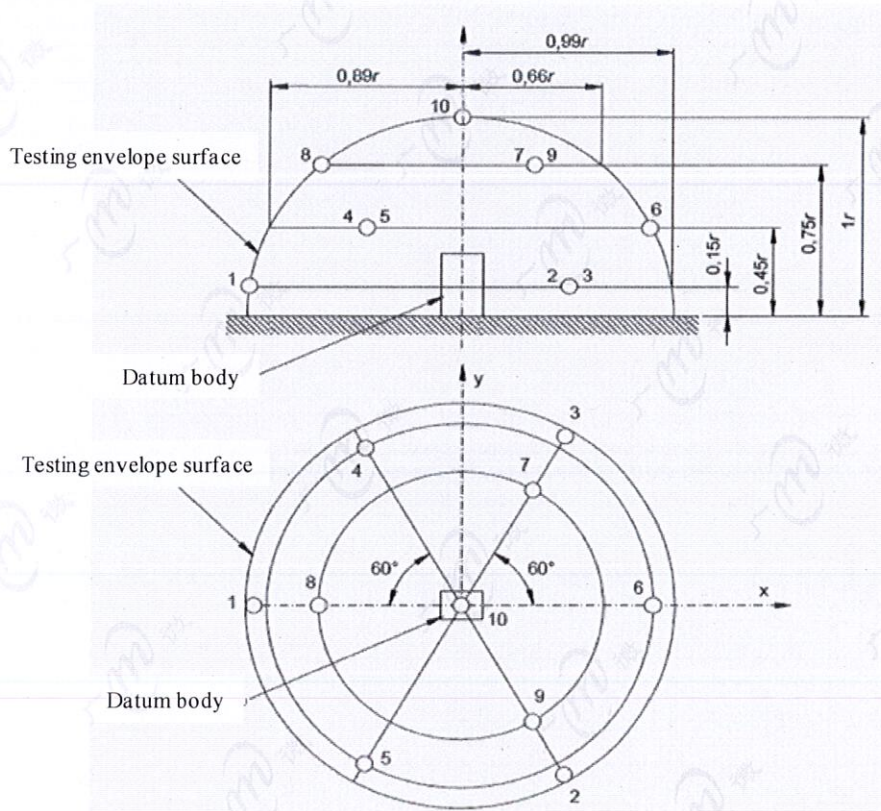

Test Results

Number of Sample	Average Sound Pressure Level dB(A)	Acoustic Power Level dB(A)
KJ20181785-1	≤ 12.0	≤ 23.5

End of report

Editor

任萍华

Checker

王长

Issuer

李华

Date Reported





中国认可
国际互认
检测
TESTING
CNAS L0823



Statements

1. The report would be invalid under the following conditions: altered, added, deleted, copied, without the special seal for inspection or signatures by approver.
2. For the received sample, the sample information in the report is claimed by the applicant, the inspection unit is not responsible for its authenticity. The report is responsibility for the received sample only.
3. If there is any objection to the inspection report, it should be presented to the inspection unit within 15 working days from the issuance date, otherwise the report shall be deemed as having been accepted. Microbiological item is not subjected to retest.
4. The report and the name of the inspection unit shall not be used for product labels, advertisements, awards and merchandise publicity.
5. The items marked with “*” in the report are not accredited by CNAS or CMA, The items marked with “#” are not accredited by CNAS, The items marked with “+” are not accredited by CMA.
6. The test data and results of items which are not accredited by CMA, only used as scientific research, teaching or internal quality control.
7. Any ambiguity by the language which used in the report, the Chinese shall prevail.



Contact Address, 1 Jiantashan Road, Huangpu District, Guangzhou City, Guangdong Province

Test Address, (only fill in when it's different from the contact address)

Postal Code, 510663

Tel., (8620)61302671

URL, <http://www.ggtest.com.cn>